

# S3B-D90 series



## Model description:

- S3B:** Absolute angular encoders with SSI protocol for FAGOR and others.
- S3BS:** Absolute angular encoders with SSI protocol for SIEMENS® (Solution Line).
- S3BF:** Absolute angular encoders with FANUC® ( $\alpha$  and  $\alpha i$ ) protocol.
- S3BM:** Absolute angular encoders with MITSUBISHI® CNC.
- S3BP:** Absolute angular encoders with PANASONIC® (Matsushita) protocol.
- S3BD:** Absolute angular encoders with FeeDat® protocol for FAGOR and others.
- S3BD + EC-PA-DQ1-M:** Absolute encoders with DRIVE-CLiQ® protocol, for SIEMENS® (Solution Line and Sinumerik One) (\*).
- S3BBC:** Absolute angular encoders with BiSS® C protocol.

(\*). Pending approval.

## Characteristics

	S3B	S3BS	S3BF
Measurement	By means of graduated glass disk		
Accuracy	$\pm 2.5$ arc-seconds $\pm 5$ arc-seconds		$\pm 2$ arc-seconds $\pm 4$ arc-seconds
Output signals	$\sim$ 1 Vpp		–
Resolution / Maximum number of positions per turn	23 bits (8 388 608 positions) 1 Vpp: 16 384 pulses/turn	23 bits (8 388 608 positions) 1 Vpp: 16 384 pulses/turn	$\alpha i$ : 28 bits (268 435 456 positions) $\alpha$ : 27 bits (134 217 728 positions)
Maximum frequency	400 kHz for 1 Vpp signal	400 kHz for 1 Vpp signal	–
Maximum electrical speed	$< 1500 \text{ min}^{-1}$		$< 3000 \text{ min}^{-1}$
Supply	3.8 to 14 V DC; $< 250 \text{ mA}$ (at 5V without load)		
Maximum cable length	75 m (1)	100 m	50 m
Maximum mechanical speed	10000 $\text{min}^{-1}$		
Inertia	Rotor: $25 \cdot 10^{-6} \text{ kgm}^2$		
Starting torque	$< 0.01 \text{ Nm}$		
Load on the shaft	Axial: 10 N Radial: 10 N		
Vibration	100 $\text{m/s}^2$ (55...2000 Hz) IEC 60068-2-6		
Shock	200 $\text{m/s}^2$ (6 ms) IEC 60068-2-27		
Operating temperature	0 °C ... 60 °C		
Storage temperature (in its packaging)	-20 °C...60 °C		
Weight	0.57 kg		
Protection	IP 64 DIN 40050 (standard) > IP 64 (DIN 40050) using pressurized air at 0.8 $\pm 0.2$ bar in angular encoders (3)		
Connection	With built-in connector		

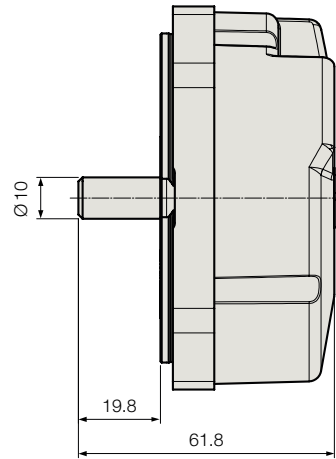
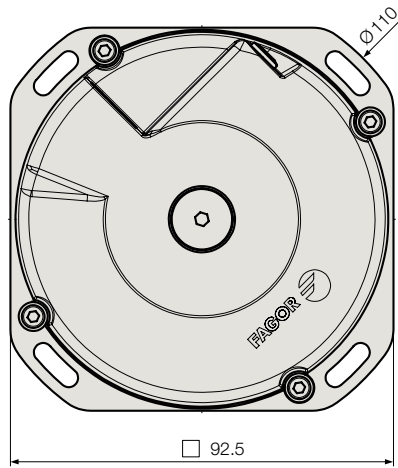

Dimensions in mm

Additional information can be found in the technical documentation and installation manual available on the website [www.fagorautomation.com](http://www.fagorautomation.com)

## Order identification

Example of Angular Encoder: **S3BF-28-D90-2**

S3	B	F	28	D90	2
<b>Type of shaft:</b> • S3: Solid shaft	<b>Letter identifying the absolute encoder</b>	<b>Type of communications protocol:</b> • Blank space: SSI protocol (FAGOR) • D: FeeDat® protocol (FAGOR) (1) • S: SSI SIEMENS® (SL) protocol • <b>F: FANUC® (α and αi) protocol</b> • M: MITSUBISHI® CNC protocol • P: PANASONIC® (Matsushita) protocol • BC: BiSS® C protocol	<b>Absolute positions per turn:</b> • 23 bits (8 388 608 positions) • 26 bits (67 108 864 positions) (2) • 27 bits (134 217 728 positions) (3) • <b>28 bits (268 435 456 positions) (4)</b>	<b>Outside diameter:</b> • D90: 90 mm	<b>Accuracy:</b> • Blank space: ± 4 arc-seconds (± 5 arc-seconds for SSI models) • <b>2: ± 2 arc-seconds</b> (± 2.5 arc-seconds for SSI models)

(1) Plus EC-PA-DQ1-M with DRIVE-CLIQ® protocol for SIEMENS® (Solution Line and Sinumerik One).

(2) Only for purely digital models, not available for SSI models.

(3) Only for compatibility with legacy products.

(4) Not available for SSI or BiSS® C models.

Notes: Not all protocol, positions per turn and accuracy combinations are possible.

S3BM / S3BP	S3BD	S3BD + EC-PA-DQ1-M	S3BBC
By means of graduated glass disk			
± 2 arc-seconds ± 4 arc-seconds			
-			
28 bits (268 435 456 positions)			(2)
-			
< 3000 min <sup>-1</sup>			
3.8 to 14 V DC; < 250 mA (at 5V without load)			
30 m	100 m	Up to 100 m (4)	50 m
10000 min <sup>-1</sup>			
Rotor: 25 · 10 <sup>-6</sup> kgm <sup>2</sup>			
< 0.01 Nm			
Axial: 10 N Radial: 10 N			
100 m/s <sup>2</sup> (55...2000 Hz) IEC 60068-2-6			
200 m/s <sup>2</sup> (6 ms) IEC 60068-2-27			
0 °C ... 60 °C			
-20 °C...60 °C			
0.57 kg			
IP 64 DIN 40050 (standard)			
> IP 64 (DIN 40050) using pressurized air at 0.8 ±0.2 bar in angular encoders (3)			
With built-in connector			

(1) Contact Fagor Automation for maximum cable length.

(2) Consult Fagor Automation for analog output signals.

(3) For more information consult the AI-1000 Filter Unit catalog.

(4) Depending on CNC model. Consult SIEMENS® documentation.